

## 5. Schmierung

3. Untere Führungsrolle und Feststellig

4. Sechskant Stahl Ausleger und  
Vorschubwelle

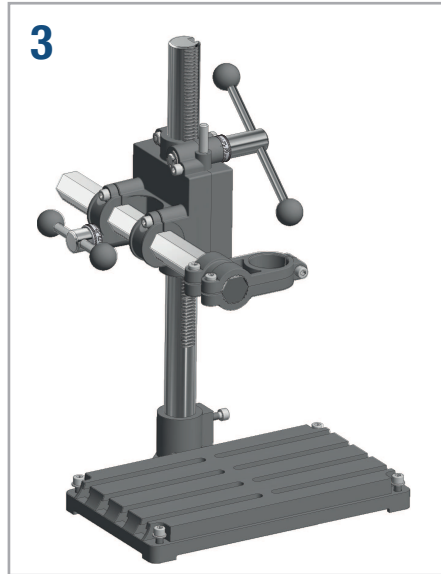

5. Sechskant Stahl Ausleger einölen

6. Stahl Säule einölen

